

The NEW FORCE in **GARAGE** Roller Shutters

COMMERCIAL

FORCESHIELD



LOW HEAD ROOM + MAXIMUM SECURITY

WHY IS COMMERCIAL FORCESHIELD SO STRONG AND SECURE?

- ✓ 5mm thick high grade aluminium tracks that are **extra wide and 2.5 times thicker and 3 times heavier** than the conventional ones.
- ✓ Extruded double walled profile.
- ✓ High security glass nylon reinforced rivotted wind lock clips.
- ✓ Category 3 cyclone rating.
- ✓ The strongest extruded shutter and tracks of this profile available in Australia.

WHY DOES COMMERCIAL FORCESHIELD LOOK SO GOOD?

- ✓ Covers a massive 5 metres in a single span.
- ✓ Rolls into a smaller neater pelmet box than conventional commercial roller shutters.
- ✓ Has a high gloss, super smooth, maintenance free, powdercoated attractive finish in a range of colours.
- ✓ Sign writers dream to paint (ask us for a price).

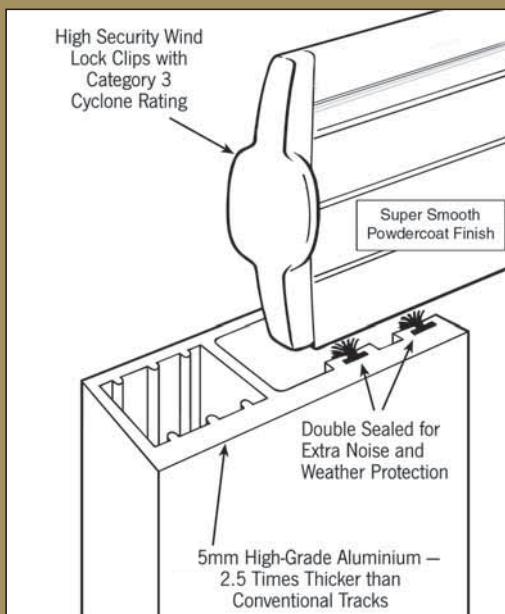

TECHNICAL DATA

Roll Size	Max Shutter Height (incl roll)	Maximum Shutter Width
205 mm	2300 mm	5000 mm
250 mm	2950 mm	5000 mm
300 mm	3500 mm	4500 mm

Profile material: Extruded High Temper T6063 Marine Grade Aluminium
Shutter Weight: 8.5kg /square metre

For a Free Measure & Quote:

ROLLASHIELD SECURITY SHUTTERS
23 Fitzpatrick Street, Revesby NSW 2212
Telephone: (02) 9792 2001 Facsimile: (02) 9772 4590
www.rollashieldshutters.com.au sales@rollashieldnsw.com

Commercial Forceshield Shutters are proudly designed and manufactured in Australia.